

Range Monitoring cum Theft Detection System

Vaibhav Bhatia

Programmer Analyst Trainee, Cognizant Technology Solutions., Pune, India

vaibhav.bhatia25@gmail.com

Abstract— In today's age of modernization, man has increased his dependence on daily routine items. Even the small household items play an important part and one cannot think life without any of these items. Life will become miserable if these items are lost or misplaced somewhere. To pose a solution to this problem, this paper presents a low cost range monitoring cum theft detection system which intends to keep a track of the items in the house and prevent their theft. This system is based on Radio Frequency technology working on a band of 434 MHz. The system developed in this paper deploys a simple yet effective technique which is different from the conventional RFID technology in which tags containing information are attached to the objects and are used for object identification. It consists of a transmitter and receiver with distinct addressing modes. The centralized receiver is connected with the different transmitters which are attached with the household items and monitors the response of these items. Each item is assigned a different address and atmost 256 different items can be tracked one at a time with this system. It monitors whether the item is within range or not, if the item is out of range which might be due to theft also, an alarm is triggered. The system works wirelessly and the range of operation has been set to 40-60 m which is the normal house range. The coefficient of determination (R^2) for the system has been found to be close to one, which accurately approximates the real data points and validates the accuracy of the system.

Keywords— Range Monitoring; Theft; Alarm; Radio Frequency; Wireless

I. INTRODUCTION

Thefts are increasing at an alarming rate and necessary steps are being taken to prevent them. There are plenty of systems which are present to detect thefts and burglary. Large systems are installed in shops and houses to prevent intrusion and robbery. With advancement in technology, Radio Frequency Identification (RFID) tags have come into play and every item inside any store has a tag or barcode associated with it to prevent its theft by others [1-3]. There are large number of applications and systems in which RFID technology is employed. Such applications include biometric applications, parking systems, pharmaceutical industries, automobile tracking and many more [4-7]. In RFID systems, tags

containing electronic information are attached to the objects which are used for object identification [8]. A duplex transmitter-receiver sends an inquiry signal to the tag and its response is read. However, using RFID tags for object identification is quite expensive which limits their use to only large industries. In today's age, it is not uncommon to misplace things and forget where we placed them. Humans have a tendency to forget, and nothing much can be done to avoid this as it involves complex neurological functions and processes. Sometimes the loss of such items creates havoc in one's life. To address this problem and to pose a solution, this paper presents a low cost and efficient range monitoring cum theft detection system which tracks the items inside the house and also prevents their theft. The system consists of a transceiver with distinct addressing modes which can track 256 items one at a time. It is well suited according to modern day needs and is economical. It can track items inside a house with a centralized receiver. Also, for an instance, if such a system is put on our suitcases while travelling in a train, the theft while passenger is asleep will trigger an alarm due to the set range and the criminal could be caught red-handed without even before fleeing the compartment. This situation could otherwise leave the bag untracked. Several such important items could be saved using the system which is handy, inexpensive and worth all the money.

II. RADIO COMMUNICATION

Radio communication employs radio frequencies of band ranging from 3 kHz to 300 GHz [9-10]. The radio signals are received and transmitted by an antenna of proper length [11]. The transmitted power depends upon the distance between the receiver and transmitter unit and varies inversely with it [12-15]. The system developed in this paper works on a frequency range of 434 MHz. The range of operation for the system has been set to 40-60 m by choosing the proper antenna length. This range is appropriate for monitoring the range of the items within a house and preventing their theft. Fig.1 shows the relationship between length of antenna and the working range of the system.

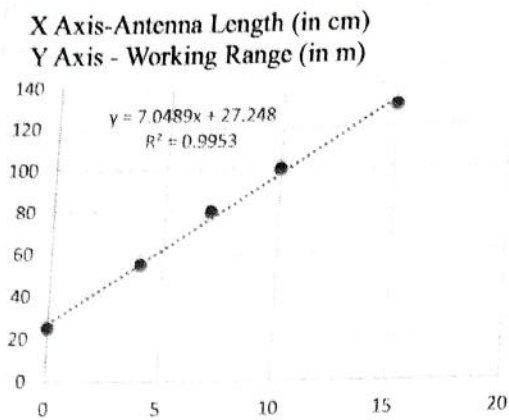

Fig.1. Antenna length vs Working range

The trend line between length of antenna and working range of the system shows that coefficient of determination R^2 is 0.9953. By varying the length of antenna, the working range of the system can be increased. The system developed in this paper works within a range of 40 to 60 m and length of the antenna used is 6 cm. The value of R^2 ranges from 0 to 1, and

it gives the proportional fluctuation of one variable that can be predicted from the other variable. Here the value of R^2 is close to 1 and it fairly approximates the real data points. As the trend line passes through all the data points quite accurately, it is easy to explain the variations. Fig.2 shows the transmitter and receiver unit of the developed system and the range of operation.

III. SYSTEM ARCHITECTURE

The system consists of a transmitter and a receiver unit which works on a frequency band of 434 MHz and accordingly. The system works in such a way that both the units always remain connected. To keep a track of the item and monitor their range, the transmitter is attached to a particular item and it is in the range of the receiver. The receiver unit has a display module attached with it which shows a message "The item is in range", if the transmitter is in range with the receiver. If the connection between these units is lost, which is due to burglary, the system triggers an alarm and displays "The item is out of range". At most 25 items can be tracked one at a time with this system.

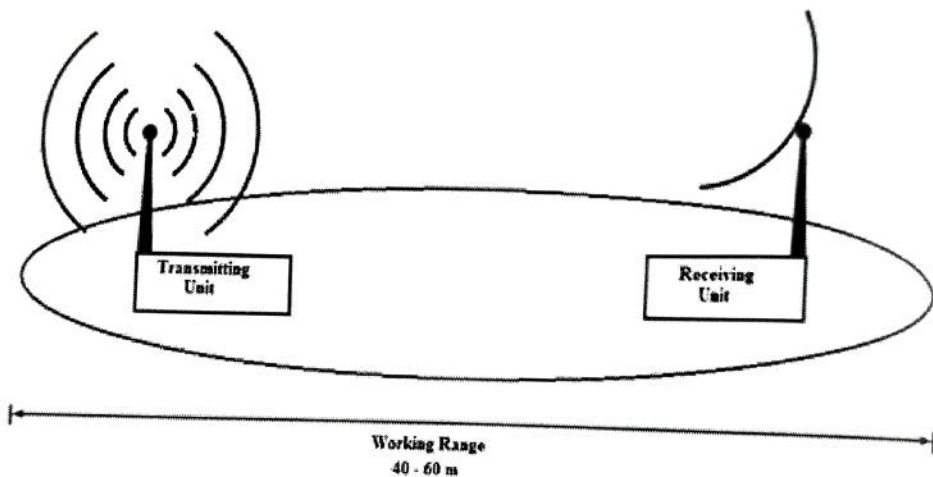

Fig.2. Working range of the system

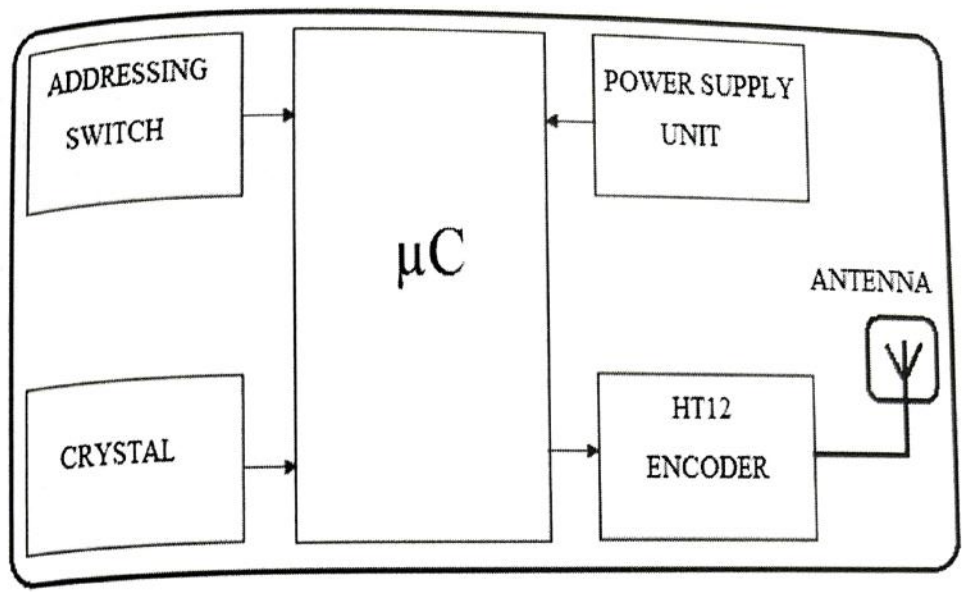

Fig.3. Block design of transmitter

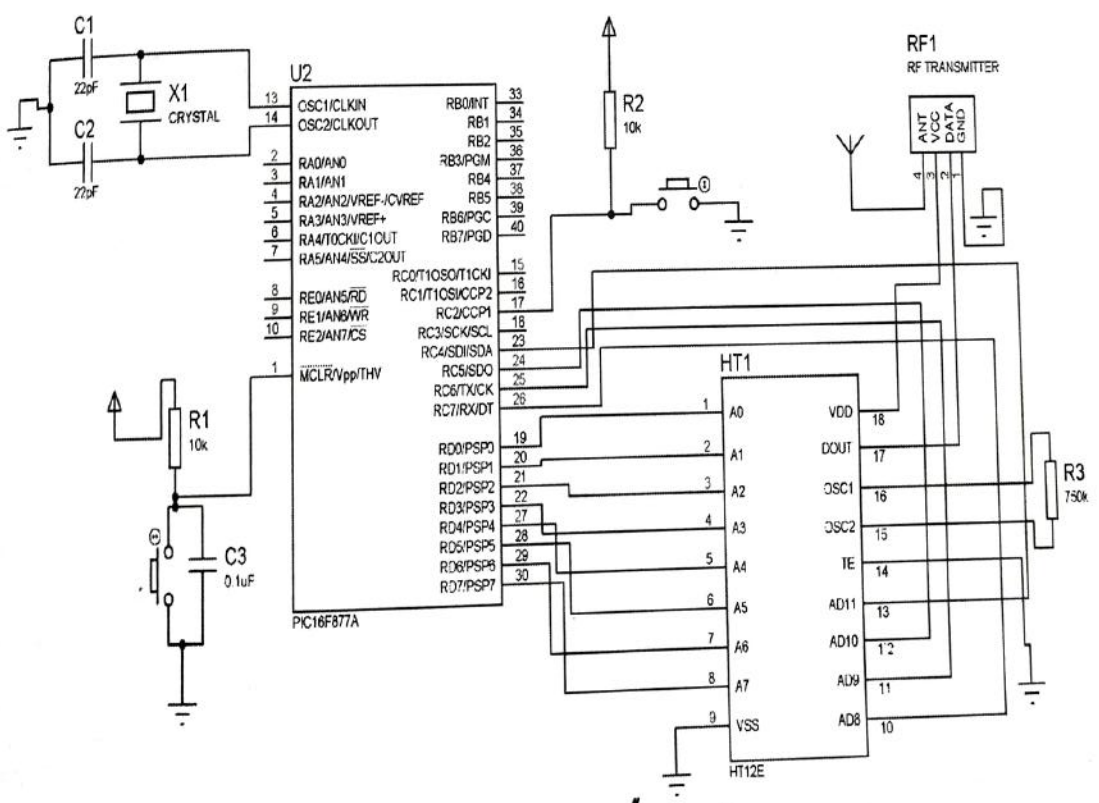

Fig.4. Simulation schematic of transmitter unit

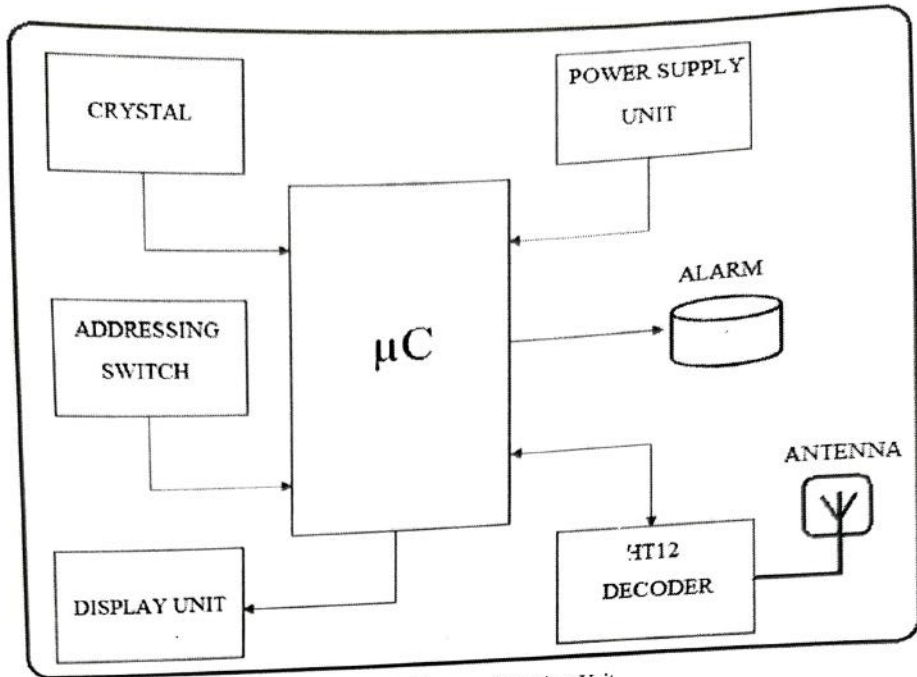

Fig.5. Block Diagram of Receiver Unit

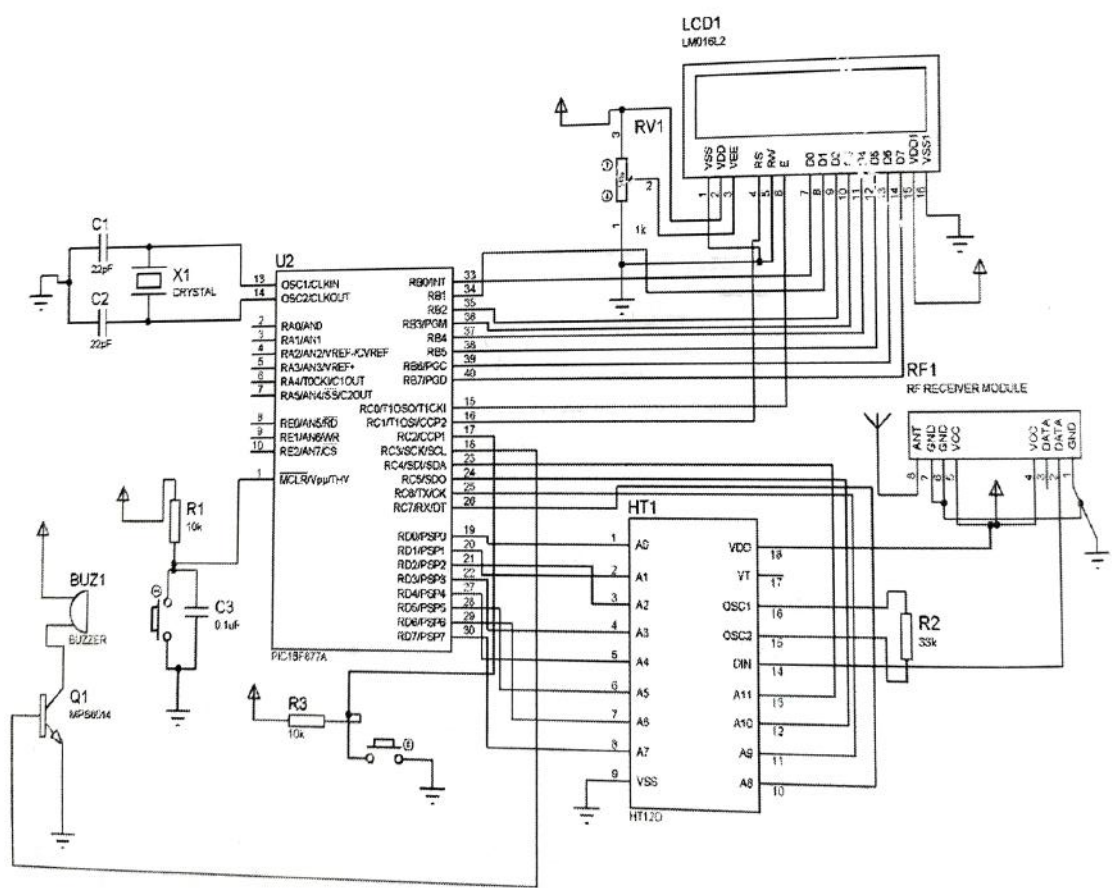

Fig.6. Simulation Circuit for Receiver

A. Transmitter Unit Design

The block design of the transmitter unit has been shown in Figure 3. It consists of a microcontroller, addressing switch, power supply unit, encoder, crystal and an antenna. The addressing switch sets the address for a particular item which is an 8-bit data and 2^8 items can be tracked. Each transmitter fitted with an item is assigned a particular 8-bit address which can be changed according to the requirements. The transmitter section works on a 5V which is supplied by power supply unit and the crystal provides clocking to the microcontroller. The encoder encodes the data to be sent. Fig.4 shows the simulation schematic of the transmitter unit.

B. Receiver Unit Design

The block diagram for the receiver unit is shown in Fig.5. It consists of a microcontroller, crystal, display unit, alarm, addressing switch, decoder and antenna. There is a centralized receiver unit for the system which can have 256 addressing modes set by the addressing switch. On adjusting the addressing modes, the receiver is connected to a particular transmitter fitted with a particular item, thus the item can be tracked easily and one can find that whether the item is within range or not. The display unit consists of a liquid crystal display which shows the message regarding the status of a particular item. The decoder decodes the data sent in the encoded form by a transmitter unit and this decoded data is processed by the microcontroller unit to take proper actions. The transmitter unit fitted with an item always remain connected with the centralized receiver and if the transmitter goes out of range, an alarm is triggered indicating that the item has been stolen.

Receiver section also requires 5V for its operation which is supplied by the power supply unit. The crystal oscillator provides clocking to the microcontroller. The simulation circuit for the receiver section is given in Fig.6.

IV. FLOWCHART OF THE SYSTEM

The logical representation of the software algorithm that has been developed for the system is given in Fig.7. The system initializes its peripherals on starting. If the item is within range i.e. the transmitter and the receiver are in range, a message showing the status "Item is in range" is displayed on the display unit. If the connection between receiver and transmitter is lost that means the item has been stolen, in this case the alarm is triggered and status updates to "Item out of range".

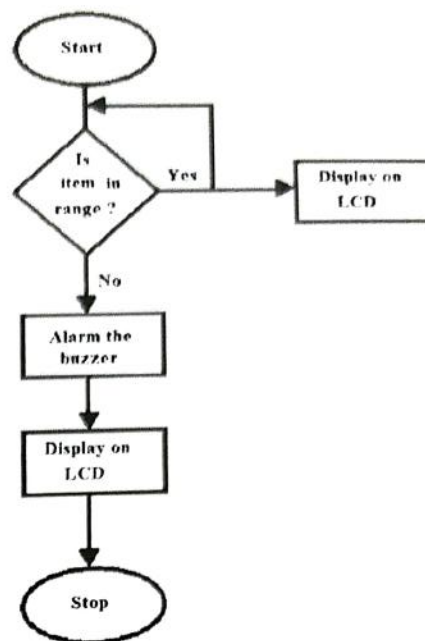

Fig.7. Flowchart of the system

V. RESULTS AND CONCLUSIONS

In this paper, a range monitoring cum theft detection system has been presented and implemented on hardware. The system has been set to a working range of 40-60 m and employs a radio frequency of 434 MHz band. The signal density decreases as the distance between the transmitter and receiver unit is increased. This system employs a simple yet efficient technique as compared to conventional RFID technology. It provides a cheap and powerful solution to the most common problem.

A. Residual plot

Residual plot is a plot between an output and input variables which is used to show whether the given regression model is appropriate according to your data. There should not be any recognizable pattern for the plotted residuals and they must be random in nature. Uncorrelated residuals are generally obtained by good regression models. The residual plot for the developed system has been plotted and shown in Fig.8.

B. Normal Probability Plot

Normal Probability Plot is graphical method which is used to check the normal distribution of the data. In this case, an approximately linear pattern is formed which shows that normal distribution is a decent model for a given set of data. The normal probability plot for the system is plotted and shown in Fig.9.

The normal probability plot and residual plot for the system has been plotted and they validate that the regression model

obtained is appropriate and thus accuracy of the system is verified. The system is fairly accurate and found to be working properly. It is appropriate according to the modern day needs.

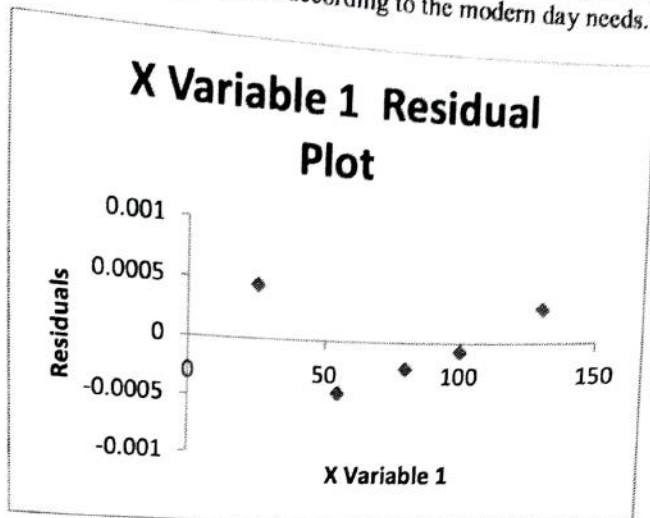

Fig.8. Residual Plot

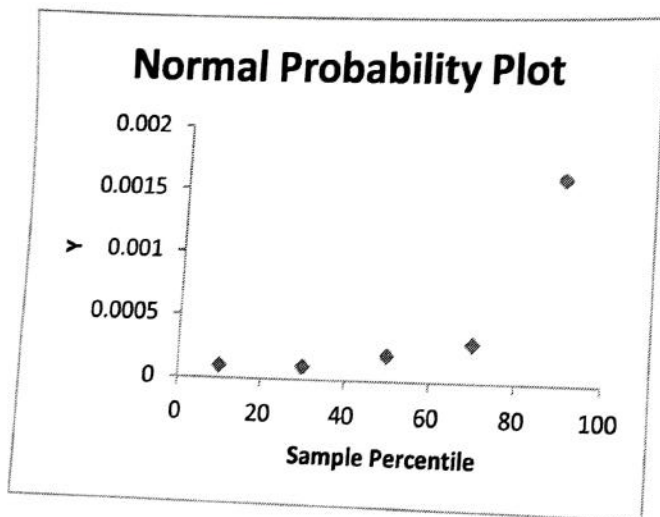

Fig.9. Normal Probability plot

VI. FUTURE SCOPE

Future implications of this product could be worked on and be improvised for more accuracy and inbuilt as a Mobile-App for convenience.

REFERENCES

[1] T. Hori, T. Wada, Y. Ota, N. Uchitomi, K. Mitsuura, and H. Okada, "A Multi-Sensing-Range Method for Position Estimation of Passive RFID Tags", IEEE International Conference on Wireless & Mobile Computing, Networking and Communications (WiMob 2008), pp. 208-213, Avignon, France, Oct. 2008

[2] Parr, R. Miesen, F. Kirsch, and M. Vossick, "A novel method for UHF RFID tag tracking based on acceleration data", IEEE International Conference on RFID, pp. 110-115, Apr. 2012

[3] N. Jinaporn., R. Ubon ; S. Wisadsud, P. Nakonrat, A. Suriya, "Secure system against asset theft by using Radio Frequency Identification Technology", ECTI-CON 2010: The 2010 ECTI International Conference on Electrical Engineering/Electronics, Computer, Telecommunications and Information Technology, pp:761 - 764, 2008

[4] G. Adams, "Pharmaceutical manufacturing: RFID -reducing errors and effort", Filtration & Separation, vol. 44, issue 6, pp17-19, July-August 2007

[5] Z. Pala and N. Inanc, "Smart Parking Applications Using RFID Technology", 1st Annual RFID Eurasia, pp: 1 - 3, 2007

[6] S. S. Saad, and Z. S. Nakad, "A Standalone RFID Indoor Positioning System Using Passive Tags", IEEE Trans. Industrial Electronics, vol. 58, no. 5, pp.1961-1970, May 2011

[7] C. Perakslis, R. Wolk, "Social acceptance of RFID as a biometric security method", 2005 International Symposium on Technology and Society (ISTAS 2005) : Weapons and wires, prevention and safety in a time of fear, pp:79 - 87, June 2005

[8] M. Ward, R. Van Kranenburg, "RFID: Frequency, standards, adoption and innovation", JISC Technology and Standards Watch, May 2006.

[9] M. Hirvonen, P. Pursula, K. Jaakkola, and K. Laukkanen, "Planar inverted F antenna for radio frequency identification", Electron. Lett., vol. 40, pp.848 -850, 2004

[10] T. Liu and P. Bahl, "Mobility Modeling, Location Tracking, and Trajectory Prediction in Wireless ATM Networks", IEEE JSAC, vol. 16, no. 6, pp.922 -936, 1998

[11] H. Hashemi, "The Indoor Radio Propagation Channel", Proceedings of the IEEE, vol. 81, no. 7, pp.943 -968, 1993

[12] G. Marrocco, "Gain-optimized self-resonant meander line antennas for RFID applications", Antennas Wireless Propag. Lett., vol. 2, no. 2, pp.302 -305, 2003

[13] T. Scharfeld, "An Analysis of the Fundamental Constraints on Low Cost Passive Radio-Frequency Identification System Design", Master's thesis, Dept. of Mechanical Eng., Mass. Inst. of Tech., Cambridge, Mass., 2001

[14] Q. Xianming and Y. Ning, "A folded dipole antenna for RFID", Proc. IEEE Antennas and Propagation Soc. Int. Symp., vol. 1, pp.97 -100, 2006

[15] P. R. Foster and R. A. Burberry, "Antenna problems in RFID systems", Proc. Inst. Elect. Eng. Colloquium RFID Technology, pp.3/1 -3/5, 1999